

# Window Installation

## Structural Installations



### These instructions are applicable for the following Structural installations:

Clad Ultimate Double Hung Magnum

Wood Ultimate Double Hung Magnum

### These instructions are applicable for the following StormPlus products:

Clad Casemaster<sup>1</sup>

Wood Casemaster<sup>1</sup>

Clad Ultimate Double Hung (CUDH)<sup>2</sup>

Wood Ultimate Double Hung (WUDH)<sup>2</sup>

Clad Direct Glaze Polygon/Round Top

Wood Direct Glaze Polygon/Round Top

#### ABSTRACT

These instructions advise the window installer/carpenter/contractor on the recommended way to install Marvin windows where structural installation is necessary, including those rated for use in Impact Zones 2 and 3. Exact installation methods for Impact Zone 4 windows are NOT included. Instead, refer to the Notice of Acceptance (see details inside).

In addition to steps for installing your window, included within are: Rough opening (RO) preparation for recessed masonry applications; RO prep and sealing details for standard wood frame construction; detailed fastening methods and more.

The procedures within these instructions are consistent with those used in testing to achieve the advertised DP rating. Contact your local Marvin dealer if your construction scenario differs from those detailed within.

**Regional standard practices, environmental conditions and codes may vary and supersede the procedures contained within. The responsibility for compliance is yours: the installer, inspector, and owner(s). See the Technical Installation Specifications inside for more details.**

<sup>1</sup>Includes Awning, Operator, Picture 1", Stationary 3/4", Round Top Operator, and Round Top Stationary.

<sup>2</sup>Includes Picture, Transom, Round Tops and Polygon

# Table of Contents

	Page
<b>Technical Installation Specifications</b> .....	2
<b>Before You Begin</b> .....	3
Installer and Builder Information, Homeowner Information, and Aftermarket Products	
<b>Step One - Rough Opening and Framing Requirements</b> .....	4
Concrete Block with Plywood Buck, Concrete Block with 2" Buck or Standard Wood Framing	
<b>Step Two - Unit Preparation</b> .....	6
Packaging, Shipping Blocks, Jamb Extension, Nailing Fin and Wood Brick Mould Casing	
<b>Step Three - Installing the Window</b> .....	7
Shimming, Plumbing and Squaring	
<b>Installation Methods and Fastener Spacing Chart</b> .....	8
<b>Fastening Methods</b> .....	9
Wood Screws/Concrete Anchors, Structural Masonry Clips, Installation Brackets	
<b>Special Fastening Systems</b> .....	11
StormPlus Ultimate Double Hung IZ3 Storm Brackets	
<b>Step Four - Final Sealing Procedures</b> .....	12
Standard Frame Construction and Recessed Masonry Applications.	
<b>Continuous Air Barrier Systems</b> .....	13
Installation, Integration, and window installation tips for house wrap and building paper applications	
<b>Window Flashing Detail (non recessed masonry)</b> .....	17
<b>Removing Interior Stops, Liners, and Fillers</b> .....	18
Removing Casemaster interior stops, Removing Ultimate Double Hung jamb carriers	
<b>Removing Sash</b> .....	19
Ultimate Double Hung and Casemaster Operators	
<b>StormPlus IZ4 Notice of Acceptance Information</b> .....	20
<b>Warranty</b>	
<b>Painting and Staining Information</b>	

# Technical Installation Specifications

The following details are specified for proper installation and for the unit to meet the advertised design pressure (DP) rating.

- Rough Opening Width: 1/4"–1" (6-25) wider than window/door frame outside measurement.
- Rough Opening Height: 1/4"–1/2" (6-13) higher than window/door frame outside measurement.
- Masonry Opening Width: 1/4"–1/2" (6-13) wider than window/door frame outside measurement.
- Masonry Opening Height: 1/8"–1/4" (3-6) higher than window/door frame outside measurement.

## Architectural Detail Manual Specifications:

- Rough Opening: Width 1" (25); Height 1/2" (13).
- Masonry Opening: Width 1/2" (13); Height 1/4" (6).
- If using less than a nominal 2" x buck in masonry openings; the rough opening must be no more than 1/2"(13) wider and 1/4"(6) taller than the outside measurement of the frame. Installation methods are limited to Jamb Screw method using 3/16" concrete screws.
- Marvin recommends the use of sloped sills on all concrete openings (either pre-cast or poured).
- **Regarding recessed masonry openings:** the window frame must not come in direct contact with masonry/concrete/concrete block. Construct framing from treated lumber or plywood and fasten to the masonry opening jambs, header, and sill. This framing must be designed (and anchored to the opening) properly to withstand certified and advertised DP ratings for your particular unit.
- For installations in typical wood frame construction (with sheathing and building paper or air barrier material) where a continuous air barrier system is used, refer to ASTM E2112-01 or reference the "**Continuous Air Barrier Systems**" section for details on preparing the rough opening and sealing the installation.
- For installations in concrete block, or masonry construction, etc., follow local codes for sealing and water management details.



**Be aware that the use of rigid sill pans and other barriers will decrease the rough opening height clearance. Adjust opening dimensions accordingly.**

- Properly flash and/or seal all windows at the exterior perimeter.
- Sealants used for installation must be Grade NS Class 25 per ASTM C920 and compatible with the building exterior, window exterior surface, and flashing/water management materials.
- Flashing materials must comply with ASTM E2112-01, section 5.13 and be compatible with all materials used in installation including panning systems, air barriers and building papers, sheathing, and the window unit.  
**Flashing material must not contain asphalt and must be compatible with flexible PVC (vinyl) when used in conjunction with nailing fin.**
- The following materials were used to develop these instructions in the Continuous Air Barrier Systems section:
  - Weather Resistant Barriers:** DuPont™ Tyvek® HomeWrap or Grade D building paper.
  - Flashing Materials:** DuPont™ FlexWrap or DuPont™ Straight Flash, DuPont™ Tyvek® Tape.
  - Sealant:** OSI® Quad Pro-Series®; solvent release butyl rubber sealant or DAP DynaFlex230™.
  - Panning System:** Marvin SillGuard™.
- **Other materials may be used but must be compatible with one another. Refer to each product's technical specifications for compatibility and usage.**
- Optional foams used for installation must be low expansion only. Foam and foam application must comply with ASTM E2112-01, SEC 5.9.2.
- Shims are required between the window frame and framing members at all locking points and at every point of attachment (excluding nailing fin and brick mould casing) as well as at all points detailed within these instructions.
- For units with flat casing install with installation brackets, structural masonry brackets, or jamb screws.
- Do not use chemically treated products for shim material.
- Fasteners penetrating chemically treated lumber must be a minimum of 0.90 oz/ft<sup>2</sup> zinc hot dipped galvanized or stainless steel type 304 or 316.
- Clad window frames must not come into direct contact with chemically treated wood products.

# Before You Begin

## Installer and Builder Information

- Read these instructions thoroughly BEFORE beginning to install your Marvin window product.
- **Always** provide a copy of these instructions for the current or future building owner.
- Plan sizing of rough opening and clearance from exterior finishing systems to allow for normal materials shrinkage or shifting (e.g. wood structure with brick veneer, allow adequate clearance at sill). Failure to do so can void the Marvin warranty coverage.
- Refer to the **Technical Installation Specifications** section for technical specifications regarding the installation of this product. These installation requirements as well as the details in this section must be followed to achieve the advertised design pressure (DP) rating of this product.
- It is the responsibility of the builder, installer and subcontractors to protect the interior and exterior of windows or doors from excessive contact with harsh chemical washes, construction material contamination and moisture. Damage to glazing, hardware, weatherstrip and cladding/wood can occur. Protect with painters tape and/or protective sheathing as required. Follow all guidelines regarding material use, preparation, personal safety and disposal.
- Refer to the enclosed painting and staining instructions on the last page for exterior and interior finish instructions.
- Contact your Marvin supplier if you have any questions regarding product and materials used in manufacturing or questions on replacement parts.





## Aftermarket Products

Alterations to Marvin products including window films, insulating or reflective interior window treatments or additional glazings can cause excessive heat buildup and/or condensation. They may lead to premature failures not covered under warranty by Marvin Windows and Doors.

Before purchasing or applying any product that may affect the installation or performance of Marvin windows contact the manufacturer of aftermarket product/glazings that are not supplied by Marvin and request written product use, associated warranties and damage coverage. Provide this information and warranties to the end user and/or building owner for future reference.

## Hazard Notations

Please familiarize yourself with the following hazard notations used throughout this instruction.

Icon	Description	Usage
	<b>Caution</b>	Mistakes or misuse could cause damage to the window or result in faulty installation and unit performance.
	<b>Warning</b>	Mistakes or misuse could result in personal injury and/or severe damage to unit, equipment, and/or structure.
	<b>Seek Assistance</b>	Help from another individual is necessary to perform this task safely and correctly.
	<b>Tips/Hints</b>	Information on alternative procedures, definitions, helpful hints.

### You Will Need to Supply

- |  |                    |
|--|--------------------|
| Safety glasses                             | Hearing protection |
| Level                                      | Square             |
| Hammer                                     | Wood shims         |
| Fiberglass insulation                      | Tape measure       |
| Perimeter sealant <sup>1</sup>             |                    |
| Backing material (foam backing rod)        |                    |
| Low expansion foam insulation <sup>2</sup> |                    |
| Appropriate fastener (see fastener chart)  |                    |
| Construction adhesive <sup>3</sup>         |                    |

### Standard Parts Shipped

Units are sent with hardware; clad units are sent with four (4) nailing fin corner gaskets. Follow installation instructions included with part if applicable. UDHM units are sent with a fastening package and supplemental installation instructions.

*NOTE: Depending on the installation method, other material may be needed to properly prepare and seal the installation such as self sealing adhesive membrane, building paper, and seam seal tape, etc.*

*NOTE: Numbers listed in parentheses ( ) are metric equivalents in millimeters rounded to the nearest whole number.*



**WARNING: Always practice safety! Wear the appropriate eye, ear and hand protection, especially when working with power tools.**

<sup>1</sup>Sealant must be Grade NS Class 25 per ASTM C920 and compatible with building exterior and window surface.  
<sup>2</sup>Optional, use low expansion foam insulation only. Foam and foam application must comply with ASTM E2112, section 5.9.2.  
<sup>3</sup>APA rated AFG-01 spec

# Step 1: Rough Opening and Framing Requirements

This section gives requirements for framing and rough opening clearances. Masonry or concrete openings must be lined with a treated wood product (wood buck). You must fasten the buck to the masonry opening in a fashion that will withstand conditions which would be encountered under the certified and advertised DP ratings for this window. The structural integrity of this installation is only as good as the bond between the wood buck and the masonry opening. For more details, contact your Marvin representative.

*NOTE: Wood buck material thickness may vary. Illustrations show a 1/2" plywood and 2 x 4 buck. Installations using material less than 2" nominal material must use the jamb screw method of attachment and use 3/16" concrete anchors.*

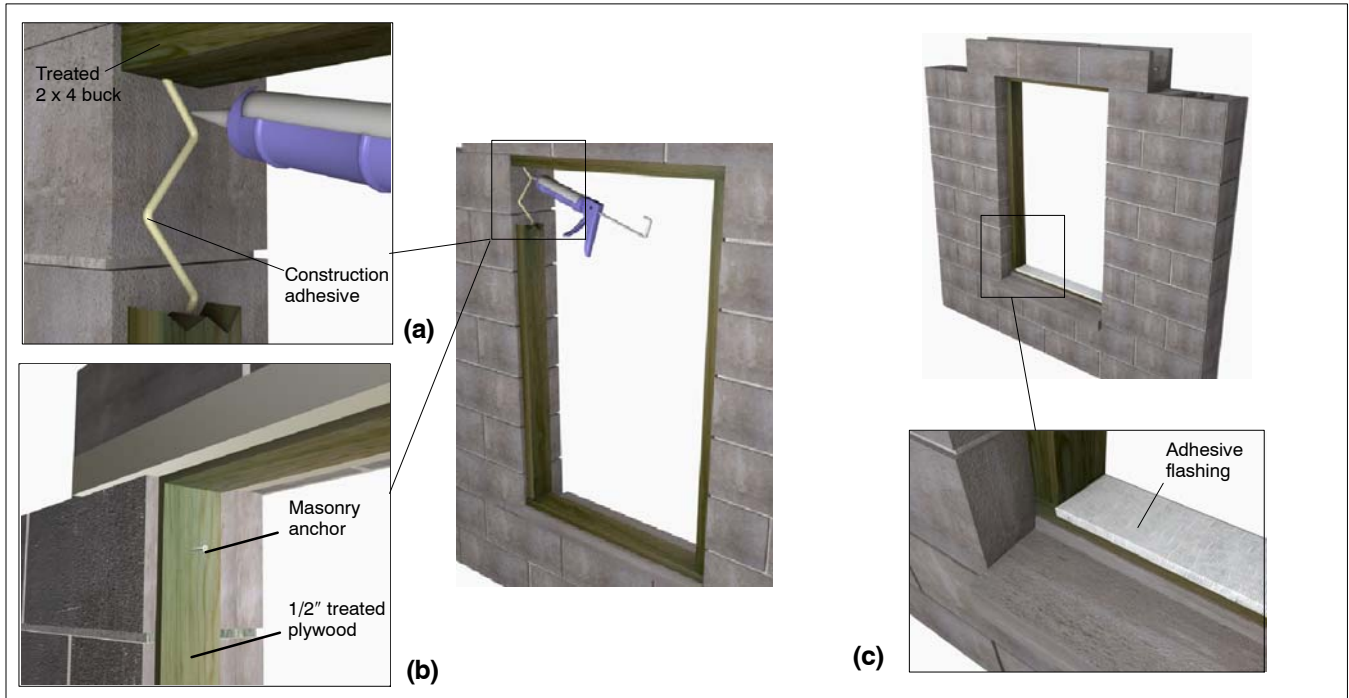

Figure 1: Preparing openings for concrete block openings.

1. On concrete block, masonry, or similar situations, line the sides, head jamb, and sill with treated lumber. Attach the lumber to the masonry opening with construction adhesive and masonry anchors which should penetrate the masonry opening by at least 1"–1 1/2" (25–38). See figure 1a and 1b.
2. For standard wood frame construction, prepare the opening following local codes, ASTM E2112–1, or follow the steps in the “**Continuous Air Barrier Systems**” section.
3. If rigid panning is used, place a bead of silicone or construction adhesive over any fasteners used to hold the panning to the sill.

*NOTE: If your installation requires screwing through the sill for structural purposes, place a bead of sealant where the screws will penetrate the rigid sill panning.*

4. The window frame must not come in contact with treated lumber. If you will not be using rigid panning or shimming at the sill, apply a barrier such as a self sealing adhesive flashing to the rough opening sill. See figure 1 c.

# Step 1: Rough Opening and Framing Requirements (cont.)



Figure 2: Preparing openings for concrete block openings.

5. **Rough openings<sup>1</sup> (RO)** should be 1" (25) wider than the outside measurement of the frame and 1/2" (13) higher. **Masonry openings (MO)** should be 1/2" (13) wider than the outside measurement of the frame or casing and 1/4" (6) higher than the outside measurement of the frame or casing. When framing rough opening, care should be taken to ensure the sill plate is level and the opening is square, straight and plumb. See figure 2.

**ATTENTION:** Be aware that use of rigid sill pans and other barriers will decrease the rough opening height clearance. Adjust opening dimensions accordingly.



**CAUTION!** If the previous conditions are not met, the installer must take corrective actions to alter the opening(s) before proceeding. It is also essential that the sheathing behind the wall be a solid surface to ensure that the unit can be secured firmly to the wall.

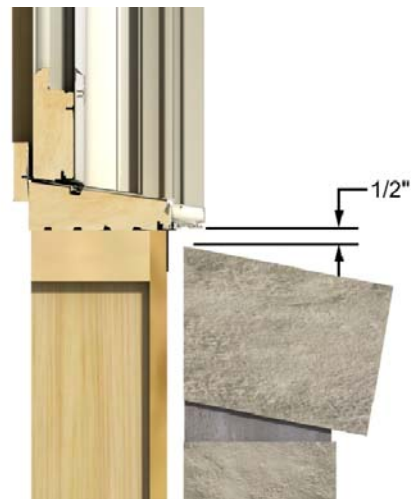

**NOTE:** On standard wood frame construction with brick veneer, make sure there is at least 1/2" (13) between bottom of window sill (or eventual placement of the window) and the top row of brick to avoid "brick bind".

<sup>1</sup>Rough opening gap must be no more than 1/4" for products certified for use in IZ4 regions.



## Step 2: Unit Preparation

1. Remove the protective packaging from the unit and dispose/recycle properly. Inspect unit for any hidden damage and report immediately to your Marvin representative. Provide the customer service number etched on one of the top corners of the glass. See figure 3.
2. Remove any shipping clips unless noted otherwise.

*NOTE: Do not remove the vinyl shipping blocks or shipping tube assembly on Ultimate Double Hungs until installation is complete (unless installing with jamb screws).*

3. If used on clad units, position the factory applied nailing fin/drip cap in the upright position. See figure 4.
4. On wood units with brick mould casing, apply sealant at the casing to frame joint along the jambs and head jamb, at the sill horn to casing joint, and at the miter corners of the casing. See figure 5.
5. If you are installing a window with installation brackets or structural masonry clips, fasten to the window now. Follow the fastener spacing in the “**Installation Methods and Fastener Spacing Chart**”. Follow the instructions provided with the brackets for details on how to fasten to unit. Ultimate Double Hung Magnum units are sent with supplemental instructions which detail how to remove the sash and jamb fillers.
6. If you will be fastening with screws through the jambs, head jambs, and sill, remove your sash and covers or liners at this time. Refer to the section, “**Removing Interior Stops, Liners, and Fillers**” and “**Removing Sash**” for details.
7. Install jamb extension before installing the window in the rough or masonry opening. Follow instructions provided with the jamb extension.

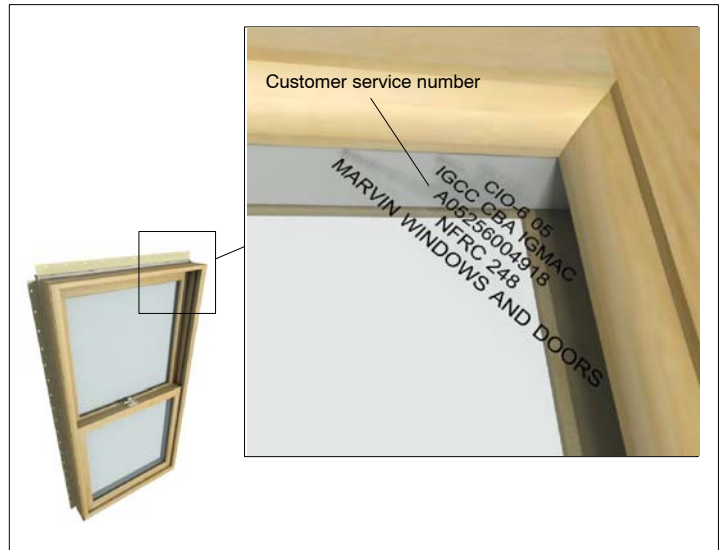

Figure 3:

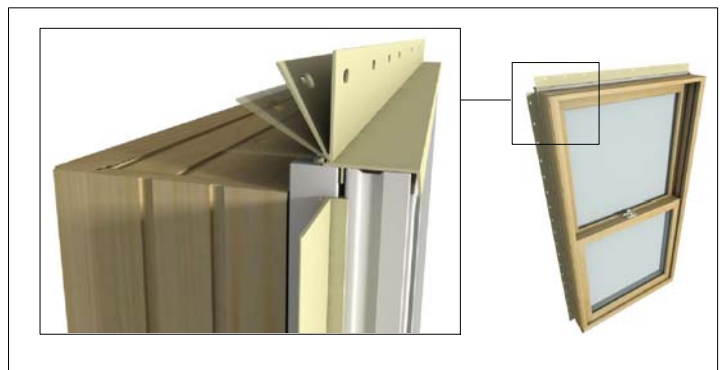

Figure 4: Extend nailing fin.



Figure 5: Apply back-caulking to BMC.

## Step 3: Installing the Window

The following steps provide details for structural fastening of the window to the opening. When installing windows with nailing fin or wood brick mould casing, it may be desirable to first attach the window using these fastening methods in conjunction with steps 1–5. Then complete the installation by fastening with structural masonry clips, installation brackets, or screws. Always follow fastener spacing and allowable methods outlined in the “**Installation Methods**” and “**Fastener Spacing Chart**” sections. On applicable construction using a continuous air barrier system, prepare the opening before installing the window. Refer to the “**Continuous Air Barrier Systems**” section for details.

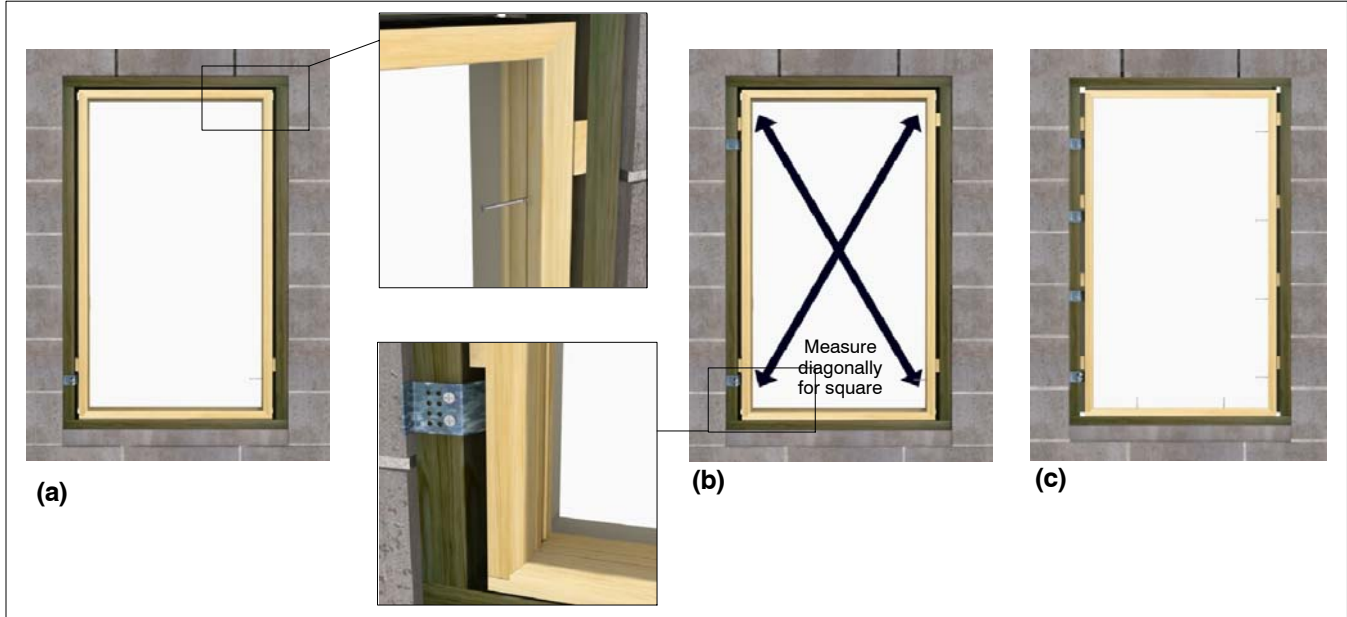

Figure 6: Plumb and square unit. (Illustration shows both masonry clip and jamb screw installation.)



**Seek Assistance:** Some large windows and/or assemblies are very heavy. Avoid injury by getting help to lift and position the window into the rough opening.

1. If rigid sill pan is not used, pan sill with alternate methods or shim under window sill to ensure it does not come in direct contact with treated lumber.
2. On some larger units such as the Ultimate Double Hung Magnum, it may be necessary to remove the sash prior to installation. See the sash removal section for details.
3. Center the window in the opening. Level at the sill and plumb the frame (interior/exterior) to desired depth.
4. Fasten and shim the jambs at the bottom with the appropriate fastener (follow instructions in the “**Fastening Methods**” section). See figure 6a. Ultimate Double Hung Magnum are sent with supplemental instructions that explain how to fasten through the jamb and head jamb.

*NOTE: Some units such as the Ultimate Double Hung Magnum and IZ3 Ultimate Double Hung, feature unique fastening systems. For these windows refer to the “**Special Fastening Systems**” section for details.*

5. Fasten and shim about 4" (102) from the top to square the unit in the opening. Take diagonal measurements of the window. When equal, the window is square in the opening. Adjust the shims and fasteners until the unit is square in the opening. See figure 6b.



**CAUTION: Proper shimming is extremely important. Under-shimming or over-shimming will result in bowed jambs and or head jamb. Both conditions can contribute to improper window operation and performance.**



**Installation Tip:** On operating units, one method to ensure that the unit is installed square is to check the reveal (gap) between the operating sash and the frame. An even reveal around the entire sash generally indicates a correctly installed unit and will ensure smooth operation.

6. Complete shimming and fastening at locations and spacing specified in the “**Installation Methods and Fastener Spacing Chart**”. See figure 6c.
7. Recheck the diagonals one more time to make sure the unit is square in the opening. Adjust fasteners as necessary to bring to square.
8. Once the unit is installed square and plumb, operate the sash (on operable units) to make sure it is operating properly. If not, you may have to make some additional adjustments to the shims and fasteners.
9. If removed, replace your stops, covers, and liners.



# Installation Methods and Fastener Spacing Chart

**IMPORTANT:** Follow **ALL** fastener methods in the corresponding box.  
Example: If the box contains A,B,E; follow all instructions for A,B,E.

Product	Installation Method							
	Wood BMC/Flat Casing		Masonry Clips		Screws			
	StormPlus Impact Zones	Fastener Method	StormPlus Impact Zones	Fastener Method	StormPlus Impact Zones	Fastener Method	Jamb Fastener Length	Sill Fastener Length
CCM Awning			2, 3	C, E	2, 3	D, E	3"	2"
CCM Operator			2, 3	C, E	2, 3	D, E	3"	2"
CCM Round Top Operator			3	C, E	3	D, E	3"	2"
CCM Picture 1"			2, 3	C, E	2, 3	D, E	3"	2"
CCM Picture Round Top 1"			3	C, E	3	D, E	3"	2"
CCM Stationary 3/4"			2, 3	C, E	2, 3	D, E	3"	2"
CCM Round Top Stationary 3/4"			3	C, E	3	D, E	3"	2"
CDG Polygon			2, 3	C, F	2, 3	D, E*	3"	3"
CDG Round Top			2, 3	C, F	2, 3	D, E*	3"	3"
CUDH			2, 3**	C	2, 3	D	2 1/2"	N/A
CUDH Picture 2"			2, 3**	C	2, 3	D, G	2 1/2"	N/A
CUDH Transom 1 5/8"			2, 3**	C	2, 3	D, G	2 1/2"	N/A
CUDH RT/Polygon			3**	C	3	D	2 1/2"	N/A
CUDH Magnum			N/A	C	N/A	H	Supplied	N/A
CUDH Magnum Picture/Transom			N/A	C	N/A	H	Supplied	N/A
WCM Awning	2, 3	A, B, E	2, 3	C, E	2, 3	D, E	3"	3 1/2"
WCM Operator	2, 3	A, B, E	2, 3	C, E	2, 3	D, E	3"	3 1/2"
WCM Round Top Operator	3	A, B, E	3	C, E	2, 3	D, E	3"	3 1/2"
WCM Picture 1"	2, 3	A, B, E	2, 3	C, E	2, 3	D, E	3"	3 1/2"
WCM Stationary 3/4"	2, 3	A, B, E	2, 3	C, E	2, 3	D, E	3"	3 1/2"
WCM Round Top Stationary 1"	3	A, B, E	3	C, E	2, 3	D, E	3"	3 1/2"
WDG Polygon/Round Top	A, B, F	A, B, E	2, 3	C, F	2, 3	D, E*	3"	3 1/2"
WUDH	A, B	A, B, E	2, 3	C	2, 3	D	2 1/2"	
WUDH Picture/Transom	A, B	A, B, E	2, 3	C	2, 3	D, G	2 1/2"	
WUDH Picture/Transom RT/Polygon			2, 3	C	2, 3	D, G	2 1/2"	
WUDH Magnum			N/A	C	N/A	H	Supplied	N/A
WUDH Magnum Picture			N/A	C	N/A	H	Supplied	N/A

NOTE: Units with clad brick mould casing or clad flat casing must be installed using wood screws or masonry clips.

\* Sill screws required on all sizes. Use appropriate fastener length from table above and requirements in detail "F".

\*\*StormPlus UDH IZ3 products have two storm brackets attached to each jamb. Installations using masonry brackets must have the storm brackets fastened to the RO with two #8x2 1/2" screws.

N/A: Not applicable.

**IMPORTANT:** Shims must be placed behind or above all fasteners between the window frame and rough opening.

## Fastener Methods

- A. Attach BMC with 16d casing nails 2" from each corner on all sides and spaced no more than 10" on center around the entire perimeter.
- B. Attach installation brackets to rough opening framing with one 1 5/8" sheetrock screw 6" from each corner and 12" apart on center at head jambs and jambs.
- C. Attach masonry clips to rough opening framing with two 1 5/8" sheetrock screws 5" from each corner on all sides and 12" apart on center around the entire perimeter. Angle screws 15 degrees toward the center thickness of the wood buck.
- D. Attach to rough opening framing with #8 wood screws 6" from each corner and spaced 12" on center. Screws must penetrate at least 1" from each edge of wood framing at a depth of no less than 1 1/4".
- E. On units 28" or wider, attach frame sill to rough opening framing with a #8 wood screw 5" from each corner and 15" apart on center. Screws must penetrate at least 1" from each edge of wood framing at a depth of no less than 1 1/4".
- F. Attach sills to rough opening framing with a #8 wood screw 6" from each corner and 12" apart on center. Screws must penetrate at least 1" from each edge of wood framing at a depth of no less than 1 1/4".
- G. Attach three masonry clips on both jambs within 6" of the bottom corner.
- H. Attach through all pre-drilled holes in jamb and head jamb.

## Fastening Methods

Although structural installations may involve fastening with wood brick mould casing, there are three ways to fasten your jambs to the opening for structural purposes. #8 Wood screws (or 3/16" concrete anchors), installation brackets, or structural masonry clips. Refer to the "Installation Methods and Fastener Spacing Chart" for proper fastening requirements for your particular product. Illustrations show a concrete block opening but apply to typical wood frame construction as well.

### Wood BMC

1. Fasten units using wood brick mould casing with 16d casing nails spaced at the range specified in the "Installation Methods and Fastener Spacing Chart". See figure 7.

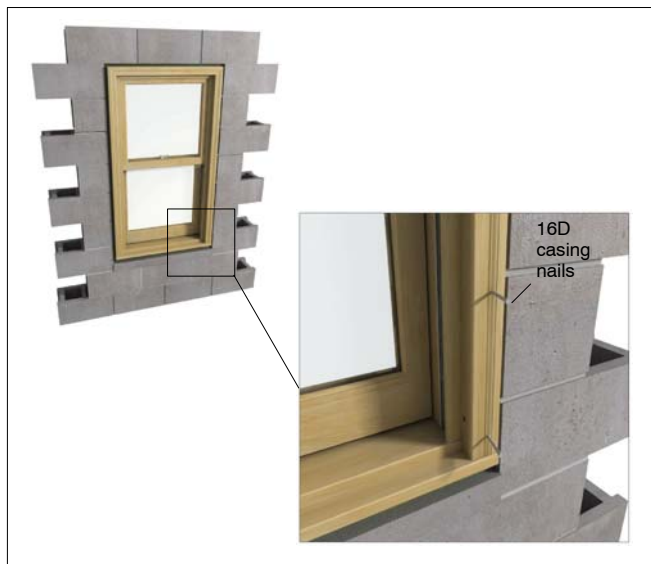

Figure 7

### Masonry Clips/Installation Brackets

1. Depending on construction method or wall type, you may need to modify the structural masonry clip to fit the opening. Once bent around the framing or opening, drill two 5/32" (5) holes in the bracket no more than 1/4" (6) from the edge of the framing. See figure 8.

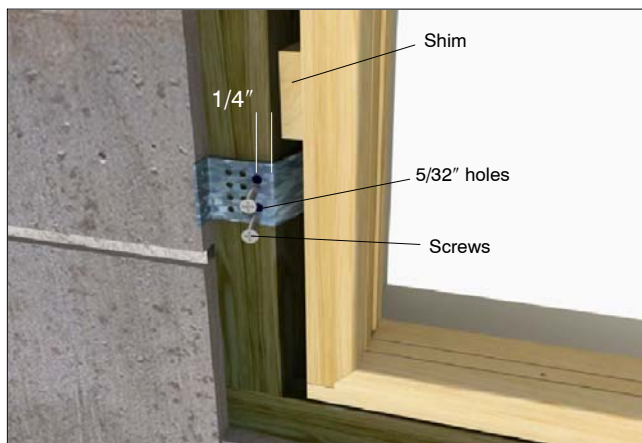

Figure 8

2. Similar to masonry clips, you may need to modify your installation brackets for proper fastening.
3. Once your brackets or clips have been wrapped around the framing/buck/opening, fasten with two #8 x 1 5/8" screws. Angle the screws approximately 15 degrees away from the window. Always shim above or behind installation brackets.

# Fastening Methods (cont.)

## Jamb/Sill Screws

1. After removing covers or liners, fasten units to the framing with #8 wood screws or 3/16" concrete anchors<sup>1</sup>. Adjust length of fastener so that it penetrates no less than 1 1/4" (32) into framing/opening. When fastening through the sill, always pre-drill and fill hole with sealant before driving the screw. Always place a shim behind or above the screw location on jambs and head jambs.

*NOTE: When using masonry anchors, be sure to follow manufacturer's guidelines for proper installation. Some types require pre-drilling.*

2. On **Casemaster** units, position the screw so that it misses any operating hardware (if applicable). With typical installations, you should be able to locate the screw in the center groove in the frame and just to the exterior of the kerf that holds the head jamb stop. See figure 9.

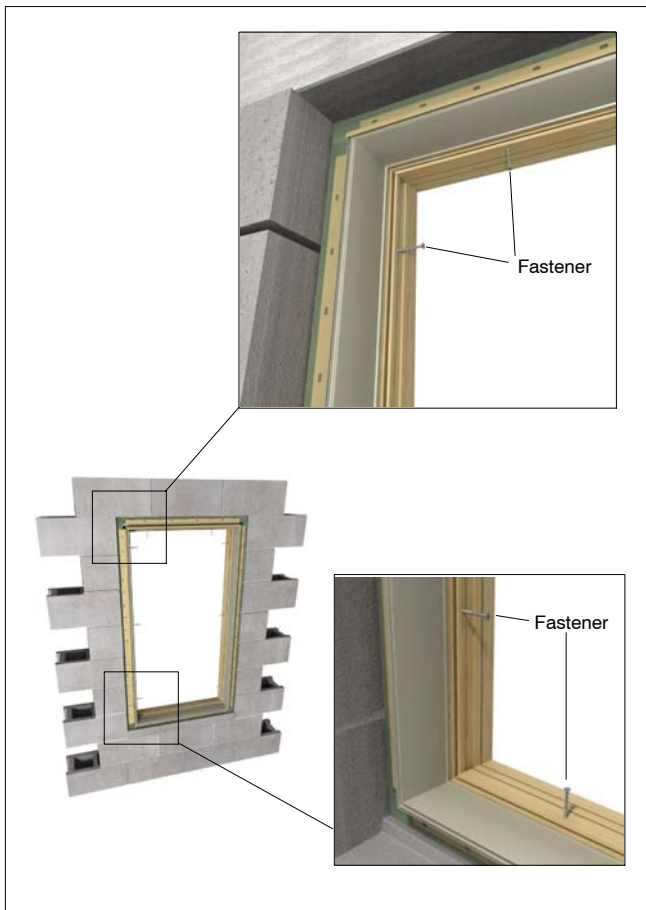

Figure 9: Exterior view, fastening through Casemaster frames.

3. On **Ultimate Double Hung** units, locate the screw in the jamb carrier kerf (jambs) and in the kerf used to hold the parting stop (head jamb). Make sure to countersink the screw so that it doesn't interfere with installation of the jamb liner and/or parting stop. See figure 10.

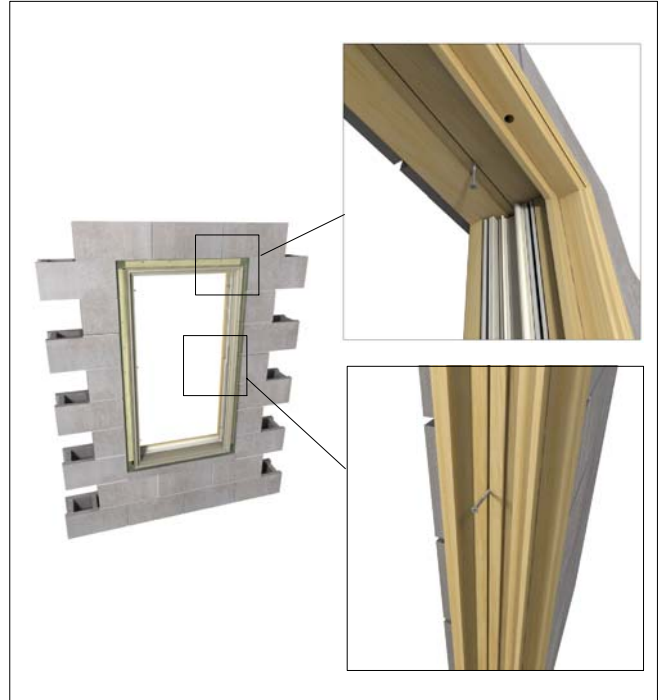

Figure 10: Exterior View, fastening through UDH frames.

4. On IZ3 Ultimate Double Hung units, fasten through the "Storm Brackets" on the jambs with two #8 x 2 1/2" (64) wood screws through the top bracket and one screw through the bottom bracket. See the "**Special Fastening Systems**" section for more details.

<sup>1</sup>Use concrete anchors when wood buck material is less than 2" nominal thickness.

# Special Fastening Systems

## StormPlus Ultimate Double Hung IZ3 Storm Brackets

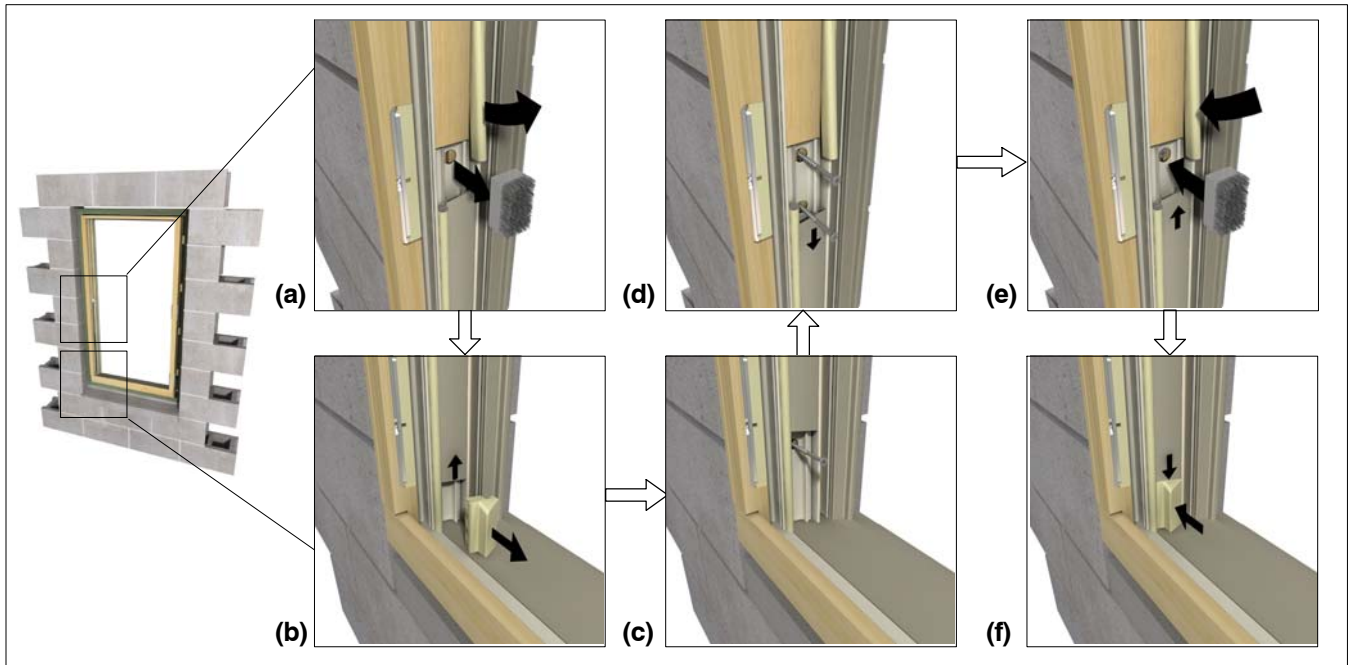

Figure 11: Fastening UDH Storm Brackets.

1. Ultimate Double Hung IZ3 units have two storm brackets attached to each jamb. If you are using the jamb screw method for installation you will notice these when you remove the clad and wood fillers. If you are using the masonry bracket method, you must first remove the check rail dust block and pull out the bottom part of the top jamb weather strip as well as remove the bottom sash stay. See figures 11a and 11b.
2. Push the clad jamb filler up as far as it will go to reveal the predrilled hole in the jamb carrier. Fasten the jambs through the storm bracket by driving one of the #8 x 2 1/2" screws through the pre-drilled hole in the jamb. See figure 11c.
3. Press the top jamb weatherstrip back into place. Slide the bottom jamb filler down as far as it will go. Fasten the jamb through the storm bracket by driving two of the #8 x 2 1/2" screws through the pre-drilled holes in the jamb. See figure 11d.
4. Slide the bottom jamb filler back up until it touches the jamb weatherstrip. Replace the check rail dust block and the bottom sash stay. See figures 11e and 11f.

5. Extend storm brackets during inclement weather by inserting a stick pin, nail, or pen through the hole in the bracket. Then slide the bracket away from the window frame as shown in figure 12.



Figure 12: Using storm brackets



**WARNING: IZ3 storm protection for CUDH operators requires that storm brackets be put in the extended position.**

**If the homeowner will be away from home for any period of time in which strong winds are possible, it is recommended that the storm brackets be pulled out to the extended storm ready position before leaving home.**

## Step 4: Final Installation Procedures

This section does not include details on sealing installations that incorporate a continuous air barrier system such as house wrap or building paper in standard wood frame construction. For flashing details in this application refer to the section, “**Continuous Air Barrier Systems - Flashing the Installation**”.

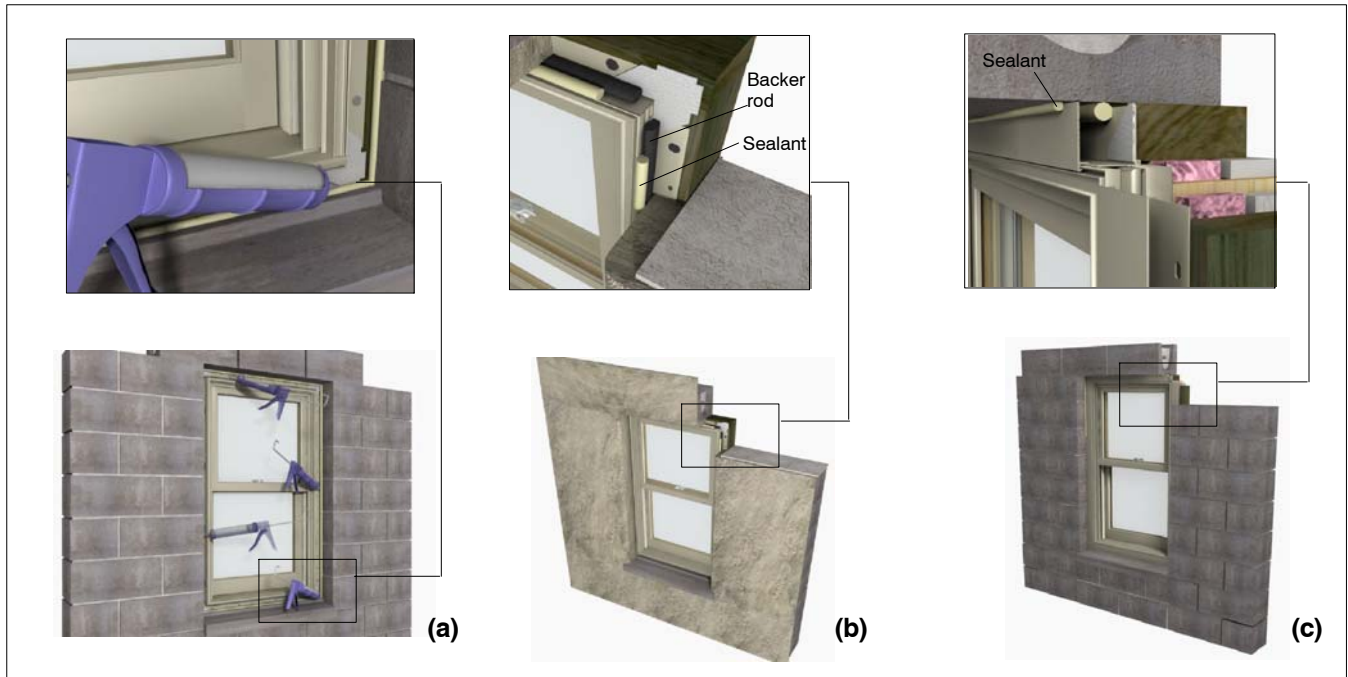

**Figure 13: Sealing recessed masonry openings**

1. Place a bead of sealant at the wood buck to masonry joint. See figure 13a.
2. For recessed masonry applications, Marvin recommends sealing at the buck to frame joint with appropriate width backer rod and sealant around the entire perimeter. Finish as applicable local code dictates. See figure 13b.
3. In some situations such as recessed masonry openings, you can use frame expander or other clad accessories to finish the exterior. If this is the case, apply a bead of sealant between the accessory and the masonry at the head jamb and jamb sections. Leave the sill portion unsealed to allow water to escape. See figure 13c.

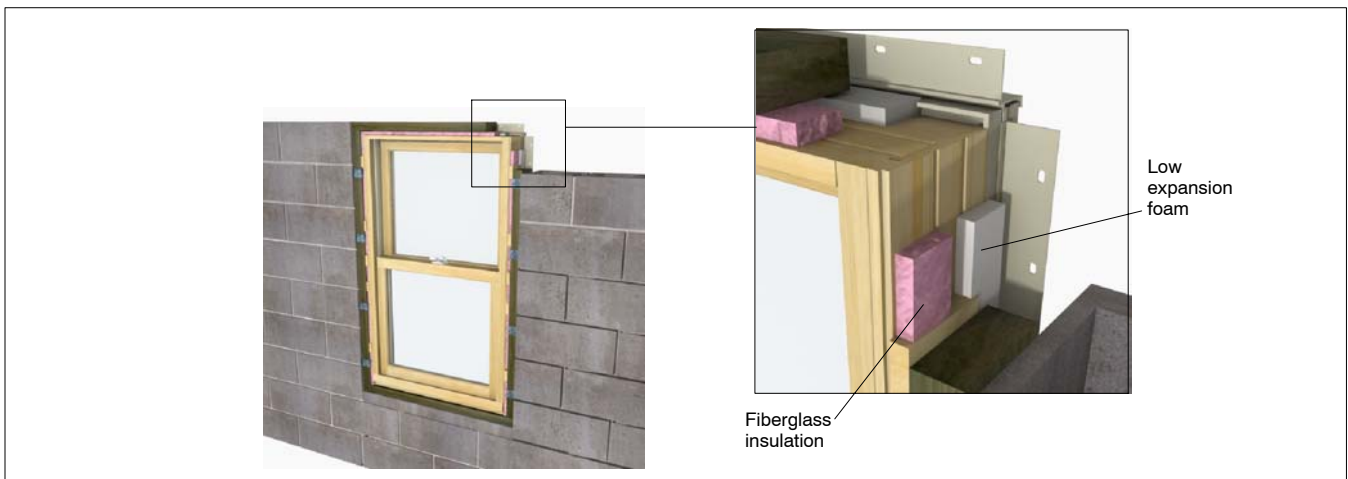

**Figure 14: Insulating the rough opening**

4. Apply a 1"–2" (25–51) thick bead of low expansion foam insulation on the back side of the nailing fin, brick mould casing or other trim. Do not apply too much as it is possible to bow the jambs. Now insulate loosely around the window with fiberglass insulation. See figure 14.
5. **Interior and mullion trim:** Install mullion trim after interior trim or casing is applied. On Ultimate Double Hung units, be sure to use nails and staples that are no longer than 3/4" (19). Place fasteners at least 1" (25) from the edge of interior jamb liner.



# Continuous Air Barrier Systems – Preparing the Opening

The following section shows the recommended rough opening preparation for both air barrier and building paper scenarios where a flanged, rigid sill pan is used. Refer to the “Rough Opening Preparation–Alternative Method” section if you do not use a rigid sill pan. Refer to ASTM E2112-1 for the other situations not covered in this document.

## Air Barrier Applications

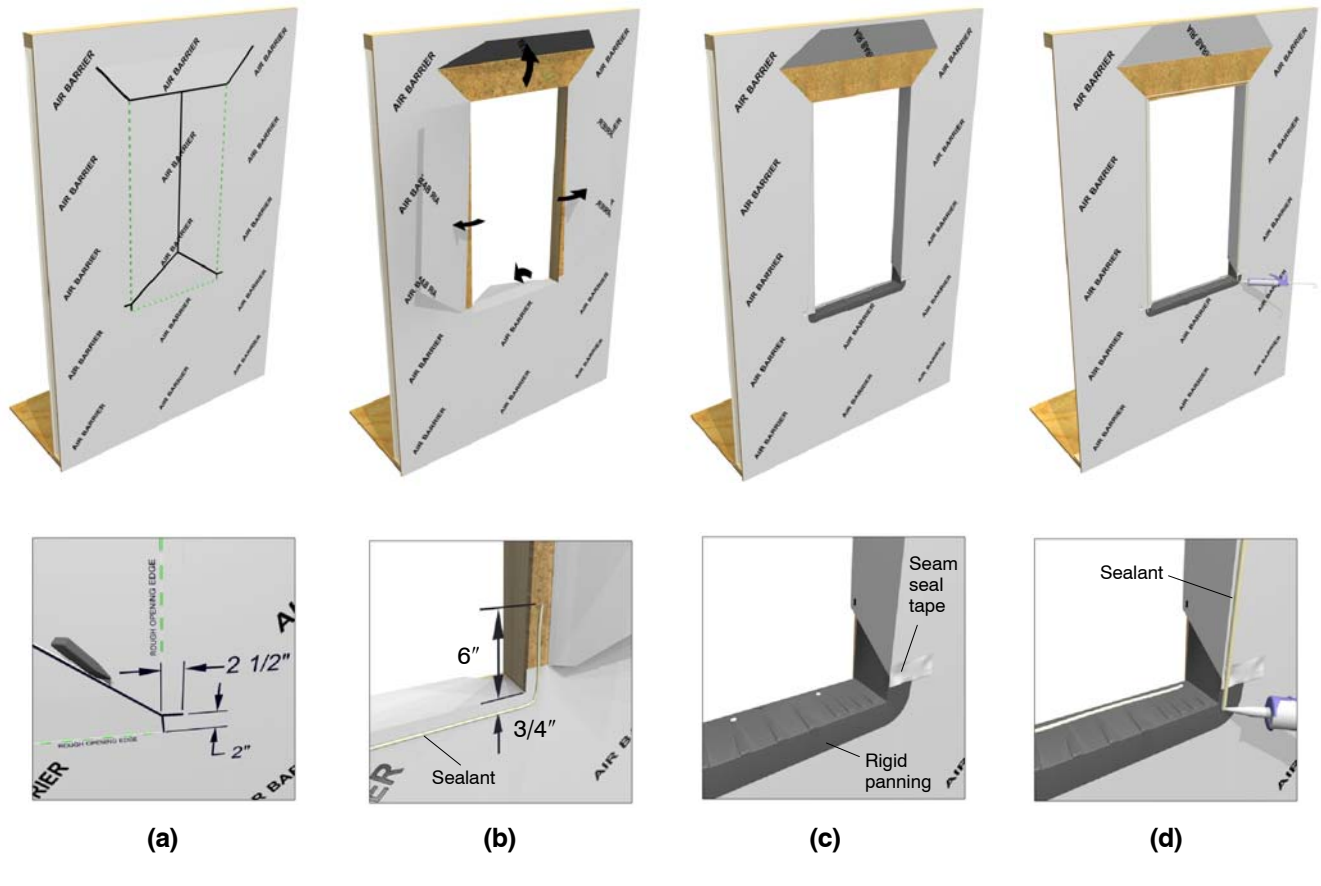

Figure 15: Rough opening preparation for construction methods using a continuous air barrier system and rigid sill panning.

1. Trim air barrier across top of head jamb. Trim up from the bottom corners about 2" (51) (or half the height of the panning flange) and then make an additional horizontal cut about 2 1/2" (64) wide (or the width of the panning flange). From the horizontal cut, make two 45 degree cuts toward the center. Cut vertically from the head jamb to where the two 45s meet. See figure 15a.
2. Flip top flap up and tack in place temporarily. Fold sill portion to the interior and tack in place. The side flaps should be loose until rigid panning is installed. See figure 15b.
3. Run a bead of sealant approximately 3/4" (19) from the edge of the opening. Start the bead about 6" (152) up from the sill (or the height of the sill panning). See figure 15b.
4. Install rigid sill panning following manufacturer's instructions. Wrap side flaps to the interior and tack in place. Seal the horizontal cut in the air barrier with seam seal tape. See figure 15c.
5. Apply a continuous bead of sealant 3/4" (19) from top and sides of window opening (or where casing or casing flange will contact the structure). Do not apply sealant to RO bottom. See figure 15d.

**ATTENTION:** Be aware that use of rigid sill pans and other barriers will decrease the rough opening height clearance. Adjust opening dimensions accordingly.

## Building Paper Applications

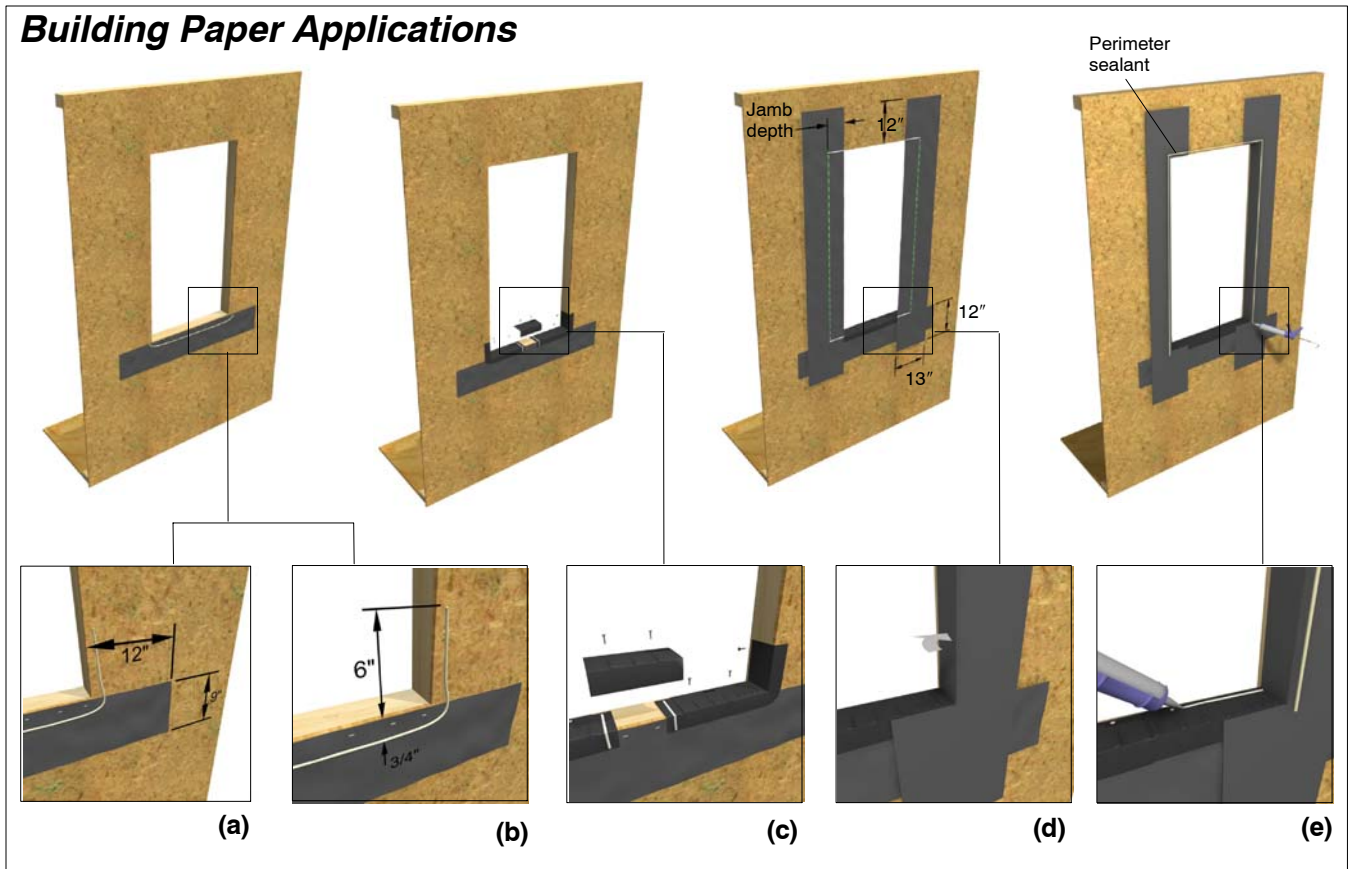

Figure 16: Rough opening preparation for construction methods using building paper and rigid sill panning.

1. Cut a 9" (229) wide strip of Grade D building paper approximately 24" (610) longer than the window rough opening width. Center the strip even with the bottom of the RO and staple along the top edge only. See figure 16a.
2. Run a bead of sealant approximately 3/4" (19) from the edge of the opening. Start the bead about 6" (152) up from the sill (or the height of the sill panning). See figure 16b.
3. Install rigid sill panning following manufacturer's instructions. See figure 16c.
4. Cut a 13" (330) piece of Grade D building paper 24" (610) longer than the RO height (adjust width for jamb depth). Tack the pieces in place, overlapping the RO by as much as the jamb depth. Use a utility knife to cut the paper even at the head jamb and sill. Fold jamb flaps to the interior and tack in place. See figure 16d.
5. Apply a continuous bead of sealant 3/4" (19) from the top and sides of window opening. Do not apply sealant to RO bottom. Seal any fasteners used to attach panning to the sill. See figure 16e.

# Continuous Air Barrier Systems - Flashing the Installation

## Air Barrier Applications

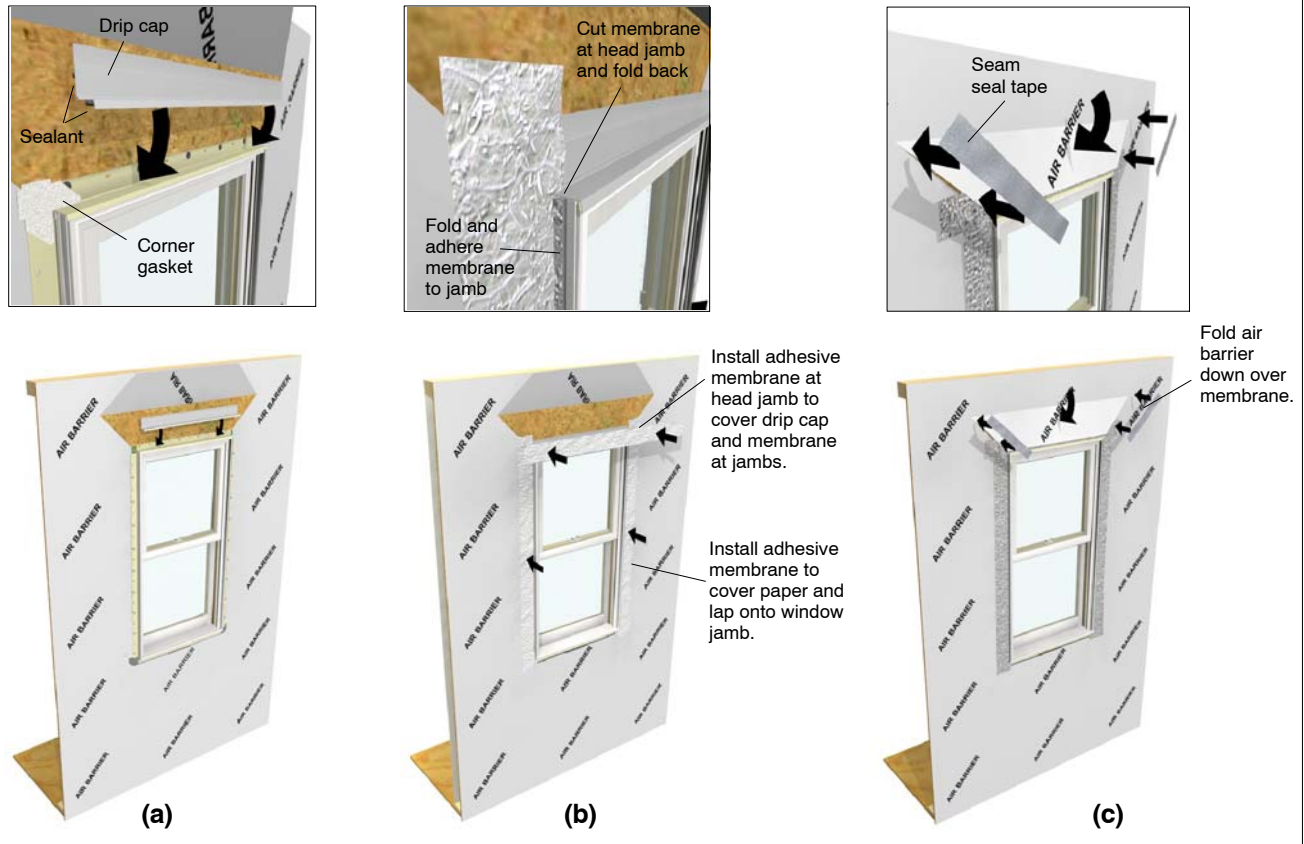

Figure 17: Sealing the installation in air barrier applications.

**NOTE:** Illustrations and text in this section refer to units built without brick mould casing or flat casing. Procedures are identical for windows with casing unless where noted.

**IMPORTANT:** Nailing fin is not designed to be a weatherproof flashing.

1. Apply nailing fin corner gaskets to each corner of the nailing fin. Follow instructions on back of gasket. **(Units with clad flat casing do not use corner gaskets.)**
2. If not completed, install a drip cap along the head jamb or head jamb casing. Be sure to apply a bead of sealant along the back sides of both vertical and horizontal surfaces of the cap that come in contact with the window, window casing, and/or sheathing. See figure 17a.

3. Lap vertical strips of self sealing adhesive membrane onto the unit or casing and out over the air barrier. Make small cuts at the head jamb to allow the membrane to fold back onto the exterior. See figure 17b.
4. Install another layer of adhesive membrane lapping onto head jamb of unit and over sheathing. Membrane flashing at head jamb should extend and cover flashing membrane previously installed at jamb. See figure 17b.
5. Fold head jamb air barrier down over the head jamb flashing. Apply seam seal tape over the diagonal cut in air barrier. Make sure the tape laps onto the unit or casing. Tape and seal any seams and fasteners directly above the unit. See figure 17c. Proceed to the **"Final Sealing Procedures"** section.

## Building Paper Applications

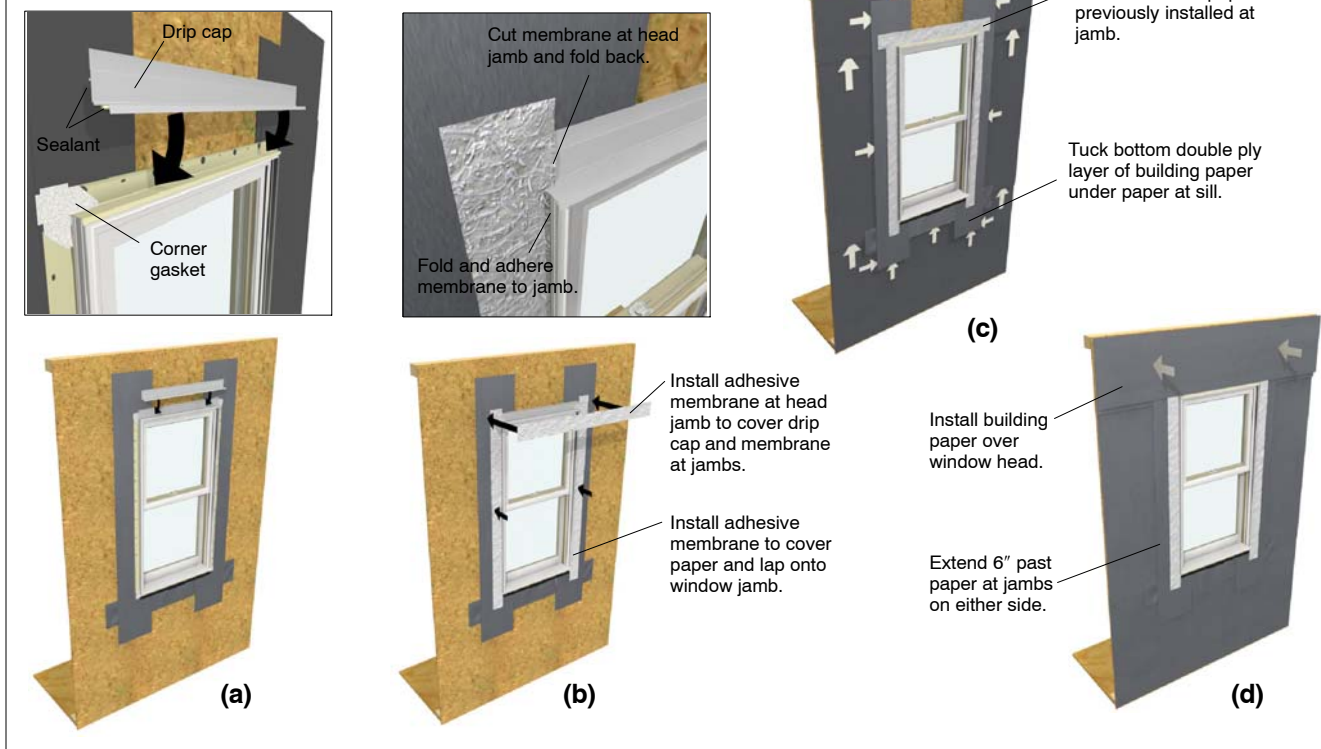

Figure 18: Sealing the Installation in building paper applications

**NOTE:** Illustrations and text in this section refer to units built without brick mould casing or flat casing. Procedures are identical for windows with casing unless where noted.

**IMPORTANT:** Nailing fin is not designed to be a weatherproof flashing.

1. Apply nailing fin corner gaskets to each corner of the nailing fin. Follow instructions on back of gasket. **(Units with clad flat casing do not use corner gaskets.)**
2. If not done already, install a drip cap along the head jamb or head jamb casing. Be sure to apply a bead of sealant along the back sides of both vertical and horizontal surfaces of the cap that come in contact with the window, window casing, and/or sheathing. See figure 18a.

3. Lap vertical strips of self sealing adhesive membrane onto the unit or casing and out over the air barrier or building paper. Make small cuts at the head jamb to allow the membrane to fold back onto the exterior. See figure 18b.
4. Install another layer of adhesive membrane lapping onto head jamb of unit and over sheathing. Membrane flashing at head jamb should extend and cover flashing membrane previously installed at jambs. See figure 18b.
5. Tuck a double ply layer of building paper under the sill flashing. At the jambs, install a double ply roll beneath the jamb flashing overlapping the previous course by at least 2" (51). Continue installing courses beyond the height of the window unit as shown. See figure 18c.
6. Size and cut a double roll of building paper to bridge the opening between the paper courses at the sides. This course should extend past the paper previously installed by at least 6" (152). See figure 18d. Proceed to the "Final Sealing Procedures" section.



## Window Flashing Detail (non recessed masonry)

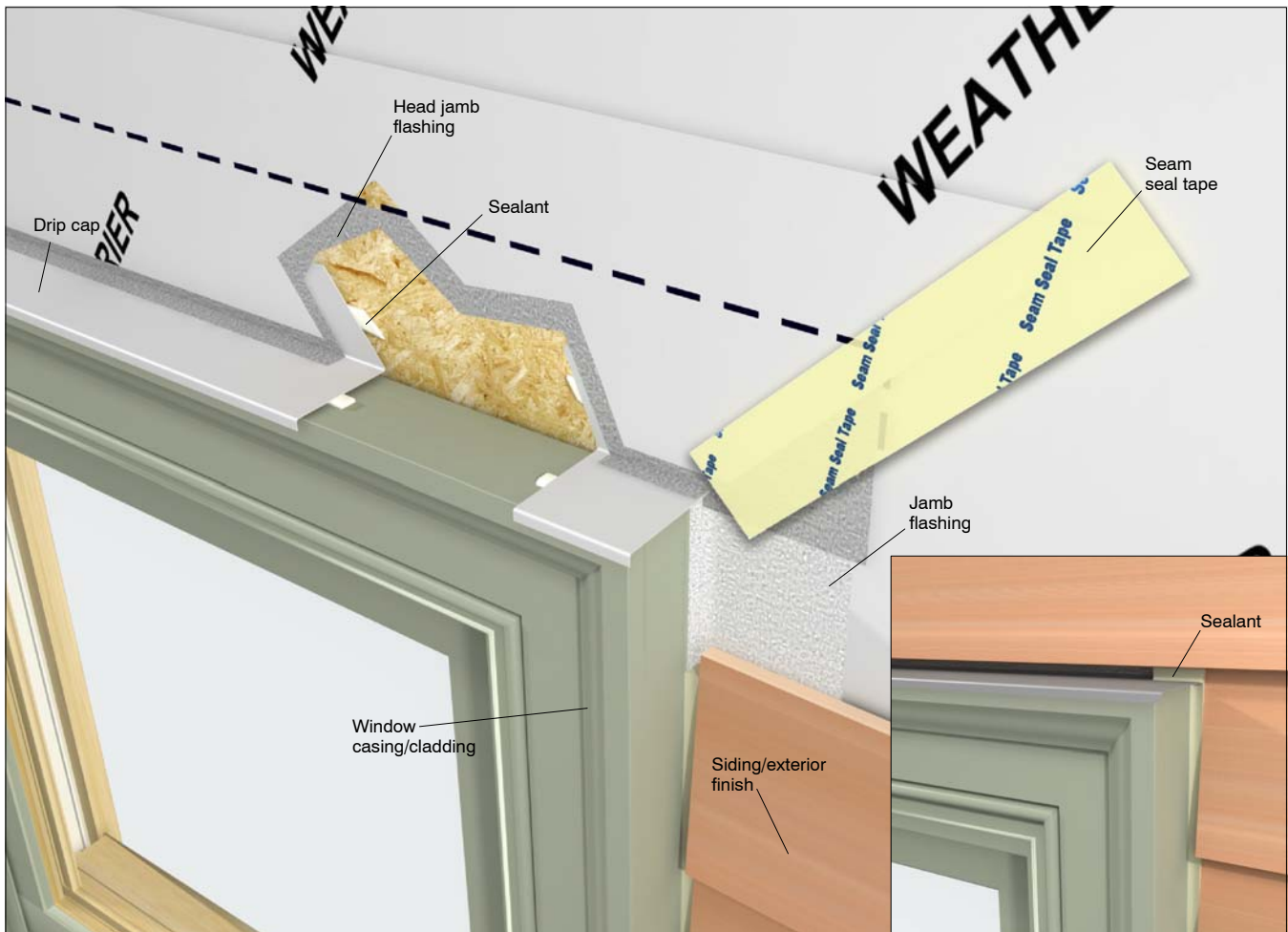

**Figure 19: Flashing windows with casing in typical wood frame construction(non recessed masonry).**

*NOTE: Figure 19 shows a window with casing but the flashing detail applies to any clad window product.*

For installations in typical wood frame construction or brick veneer (non recessed masonry openings), figure 19 shows the proper flashing detail in shingle style fashion. Once the exterior finish such as siding or brick veneer is installed, a bead of sealant should be applied between the finish and the window/window casing along the sides and approximately 1-2" (25-51) in from the ends at the head jamb. Use a backer rod when necessary.



## Removing Interior Stops, Liners and Fillers

Some structural installations that use the “jamb pinning” method require the removal of interior stops before installing the window. This section details the removal of Ultimate Double Hung (UDH) jamb liners and Casemaster operator and stationary stops. More detailed information can be found in the Marvin Service Manual.

Details for UDHM windows can be found in the supplemental instruction sent with the unit.

### Removing Casemaster Stops and Covers

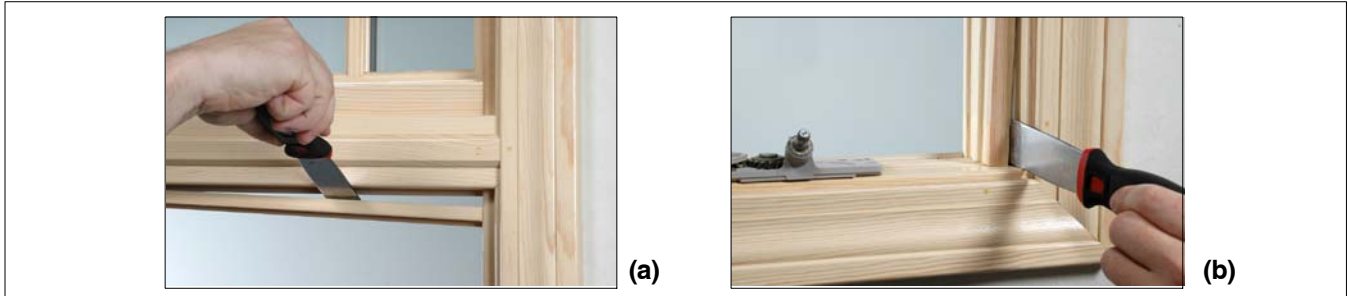

Figure 20: Removing Casemaster stops and covers.

1. Sill and head jamb covers and stops are held in place with a vinyl barb and can be easily removed by simply and carefully prying up on the stop with a sharp putty knife. Be careful not to damage the stop or frame. Occasionally the barb will stay in the frame when you remove the stop. Remove the barb with a pair of pliers and reinsert into the kerf on the stop/cover. See figure 20a.
2. Operator jamb covers are held in place by two barbs: one on the interior side and one on the exterior side shared by the frame weather strip. With the sash opened or removed, first pull the frame weather strip out of the kerf and set aside for reuse later.
3. Remove the sill and head jamb stops.
4. With a sharp putty knife, carefully pry on the interior side between the stop and the frame. Start at one end and work your way down until stop loosens. See figure 20b.

*NOTE: Stationary jamb stops are removed in the same fashion. You will need to remove the head jamb and sill covers first.*

### Removing UDH Jamb Liners

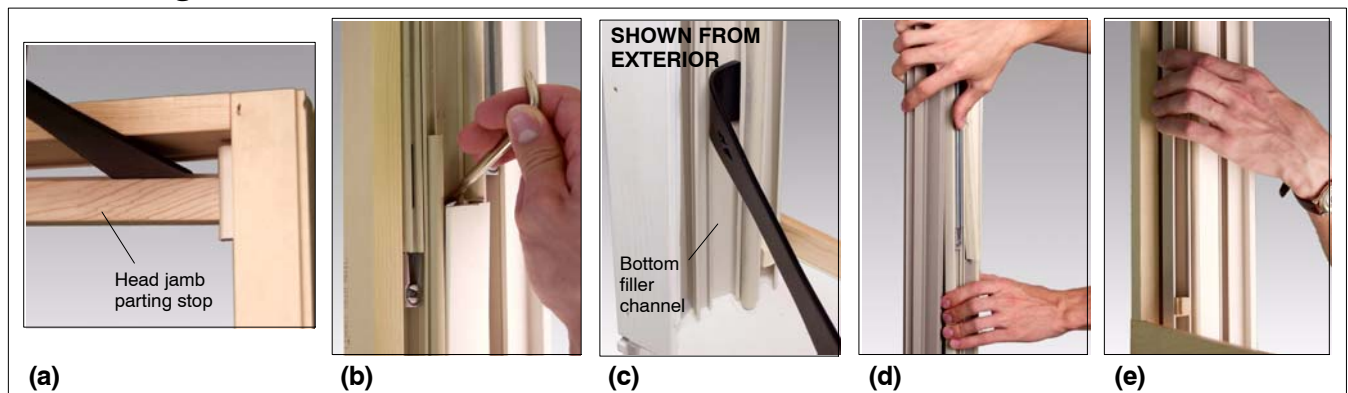

Figure 21

1. Remove the head jamb parting stop with use of a pry bar. See figure 21a.
2. Use a flatheaded tool with a 90 degree elbow to remove the lower fillers from the jamb hardware assembly. This is best done by placing the tool into the space opened by the removed checkrail pad. Loosen both corners of the jamb fillers from the notches before trying to remove them, to reduce the possibility of damage to the fillers. See figure 21b. Be sure to take care when doing so, as there is a possibility of the fillers breaking.
3. From the exterior, pry out the jamb hardware assembly using a pry bar by placing it into the bottom filler channel, hooking it into the notches on the side, and levering it out. See figure 21c.
4. When installation of the unit is complete, seat the jamb assembly facing towards the exterior first, and ease the remainder of the assembly into the jamb pocket. See figures 21d and 21e. Use of a rubber mallet may be required. If so, take the mallet and, starting at one end, work your way up the filler, until fully seated. (Use of a cloth to protect the wood and keep it clear from direct impact while hammering is suggested.)
5. Reinstall the checkrail pads and head jamb part stop.

# Removing Sash



**Seek Assistance:** Some sash on large windows are very heavy. Avoid injury by getting help to lift and position the window into the rough opening. For other products not shown here refer to the Marvin Service Manual or contact your Marvin representative.

## Ultimate Double Hung Operator Sash

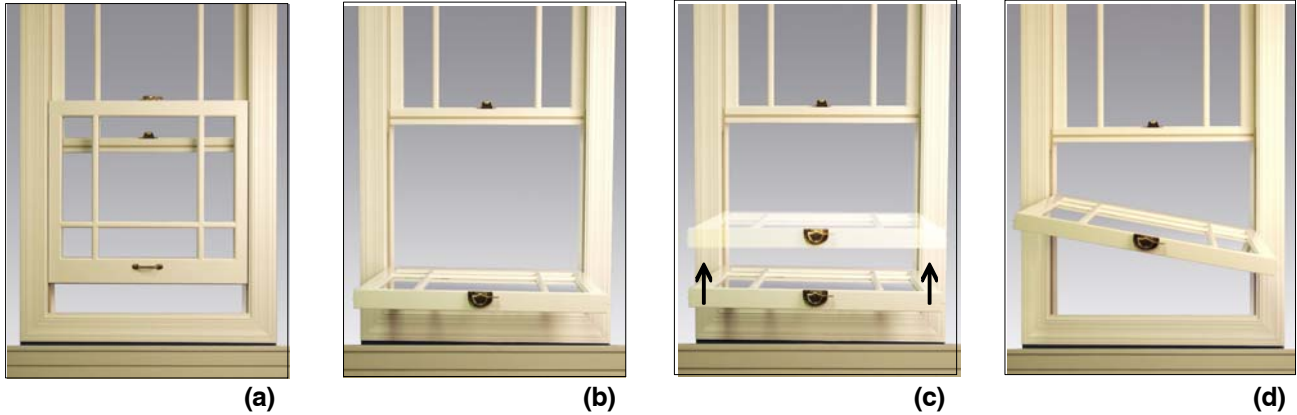

Figure 22: Tilting and removing Ultimate Double Hung Sash

1. Raise the bottom sash approximately 4" (102). See figure 22a.
2. Pull the tilt lever (nested in the sash lock base) until it clicks. Hold the lever until latches clear the unit frame when tilting. Ease top edge of bottom sash out toward you to a horizontal position. See figure 22b.
3. Lift both sides of the sash upward 2"–3" (51–76) (raising the pivot pins out of each clutch). See figure 22c.
4. Rotate the sash until the pivot pins clear the jambs and remove the bottom sash from the frame. See figure 22d.
5. Tilt and remove the top sash using the same technique used on the bottom sash. (The top sash uses tilt latches located on both sides of the top rail.)

## Casemaster Operator Sash

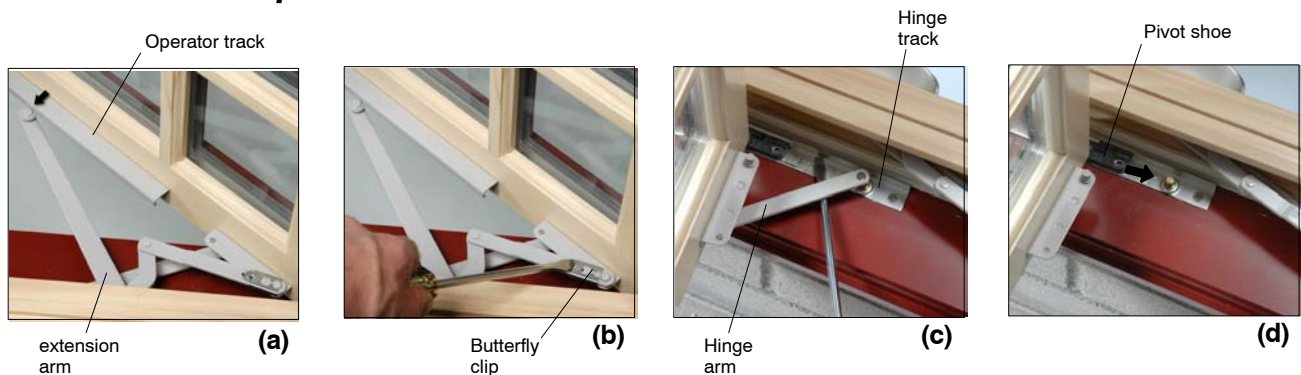

Figure 23: Removing Casemaster Operator Sash

**NOTE:** Sash with daylight openings of less than 14 1/2" (368) will use hinged single arm operator gear. Skip to step 2 for these units.

1. Crank open sash until the nylon roller on the long extension arm lines up with the arrow on the operator track. Disconnect the extension arm from the operator track by pushing the roller down through the opening in line with the arrow. See figure 23a.
2. Disconnect the butterfly clip on the short extension arm from the stud on the sash bracket. See figure 23b.
3. Push the sash open to 90 degrees. With a screwdriver or similar tool, pry the bottom hinge off from the stud on the hinge track. Repeat this on the top hinge. See figure 23c.
4. Remove the sash by sliding the entire sash on its hinge pivot shoes toward the hinge track studs. The shoes will disengage from the track when they hit the stud. Carefully remove the sash and set aside. See figure 23d.



## IZ4 Notice of Acceptance

Exact instructions for installing windows certified for use in Impact Zone 4 are not included in this publication. The installer/contractor MUST install the window(s) according to detailed drawings found in the Notice of Acceptance (NOA) to the Product Control Division of the Miami-Dade County Building Code Compliance Office (BCCO). You will be able to find the NOA drawings for each certified product on the Miami-Dade County website (exact URLs listed below), at [www.marvin.com](http://www.marvin.com), or you may obtain a hard copy by contacting your Marvin representative.

NOA	DESCRIPTION	URL
07-0524.08	Clad Casemaster Polygon/RT Picture	<a href="http://www.miamidade.gov/buildingcode/library/productcontrol/noa/07052408.pdf">http://www.miamidade.gov/buildingcode/library/productcontrol/noa/07052408.pdf</a>
07-0524.06	Clad Casemaster Operating RT/Polygon	<a href="http://www.miamidade.gov/buildingcode/library/productcontrol/noa/07052406.pdf">http://www.miamidade.gov/buildingcode/library/productcontrol/noa/07052406.pdf</a>
07-0524.07	Clad Awning	<a href="http://www.miamidade.gov/buildingcode/library/productcontrol/noa/07052407.pdf">http://www.miamidade.gov/buildingcode/library/productcontrol/noa/07052407.pdf</a>
07-0306.07	Clad Casemaster Picture	<a href="http://www.miamidade.gov/buildingcode/library/productcontrol/noa/07030607.pdf">http://www.miamidade.gov/buildingcode/library/productcontrol/noa/07030607.pdf</a>
07-0524.09	Clad Casemaster Operator	<a href="http://www.miamidade.gov/buildingcode/library/productcontrol/noa/07052409.pdf">http://www.miamidade.gov/buildingcode/library/productcontrol/noa/07052409.pdf</a>
07-0924.01	Clad Direct Glaze Polygon/Round Top	<a href="http://www.miamidade.gov/buildingcode/library/productcontrol/noa/07092401.pdf">http://www.miamidade.gov/buildingcode/library/productcontrol/noa/07092401.pdf</a>